

## Napa Pergola Assembly Instructions

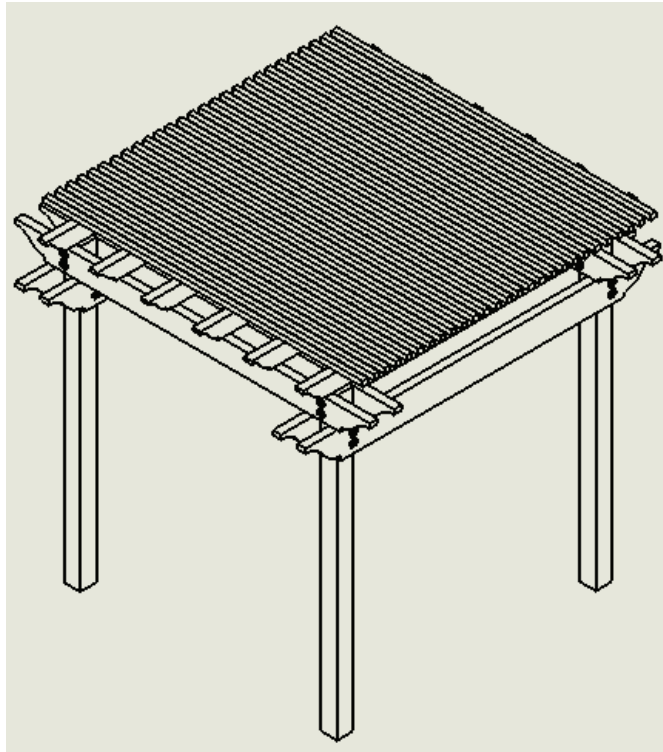

ITEM NO.	DESCRIPTION	Quantity
1	6x6 Redwood Timber Post	4
2	3x10 Redwood Timber Header- Corbelled Ends	4
3	3x8 Redwood Timber Header- Corbelled Ends	4
4	3x6 Redwood Timber Header- Corbelled Ends	6
5	2x2 Redwood Timber Lath	27
6	3/4" MALLEABLE WASHER	32
7	3/4" X 12" BOLT	16
8	3/4" HEX NUT	16

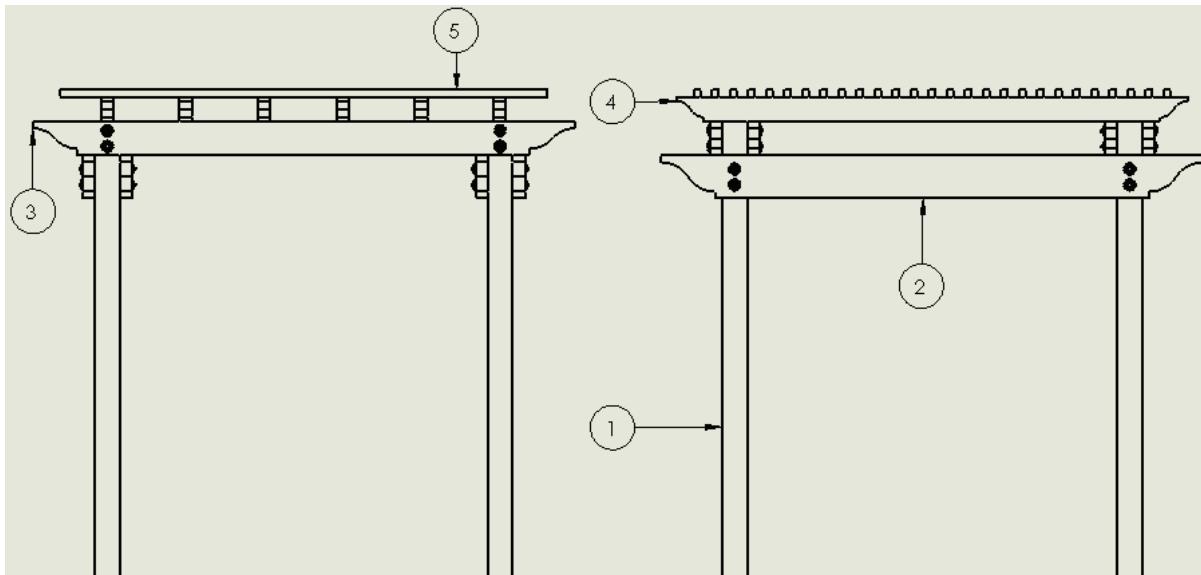

**Humboldt  
Redwood®**

**List of Tools required:**

2 People

Drill

7/8" x 8" Drill Bit

15/16" Driver bit or wrench(s)

Nails or Woodscrews (Galvanized)

Hammer

Framing Square

Bubble Level

Measuring Tape

Pencil

(8) 4ft+ Long Scrap 2x4 for use as temporary bracing.

**1) Layout Post Anchors**

On Level ground mark location of the 4x included post anchors. Ensure that diagonal measurements are equal to maintain square dimensions.

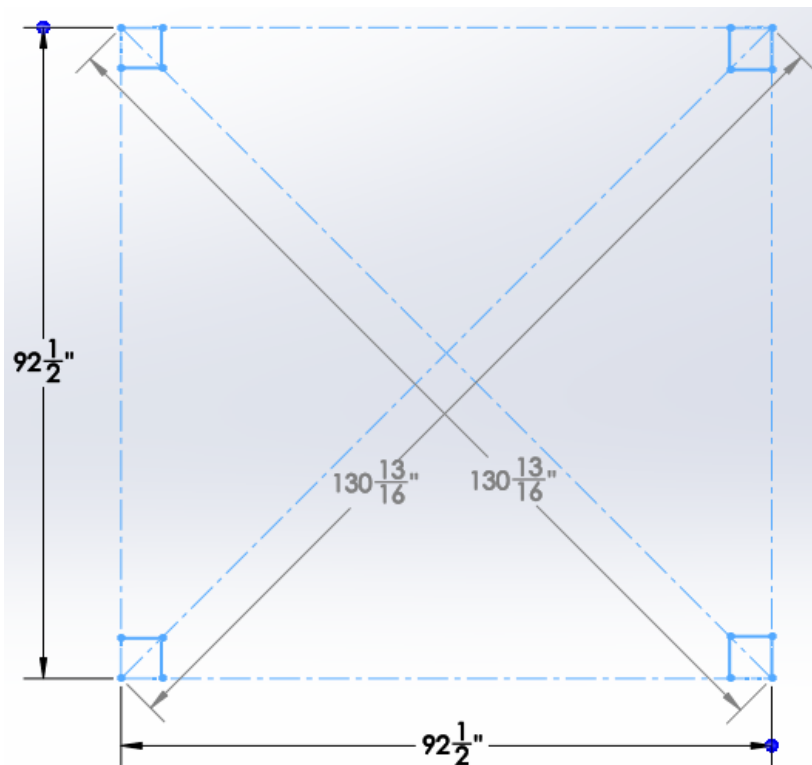

**2) Secure Post Anchors**

Install Post anchors in marked location. Consult Simpson installation instructions for proper procedure.

### 3) Assemble Posts and 3x10 Headers

With two 6x6 Post [1] laid flat on the ground measure  $7\frac{1}{2}$ " from the top edge and mark for the top of the 3x10 header. Center the pre-drilled holes of 3x10 Header [2] upon post. Ensure equal  $92\frac{1}{2}$ " spacing along the length of the posts and use a framing square and bubble level to maintain square dimensions. Mark hole location and drill holes through posts using  $\frac{7}{8}$ " drill bit.

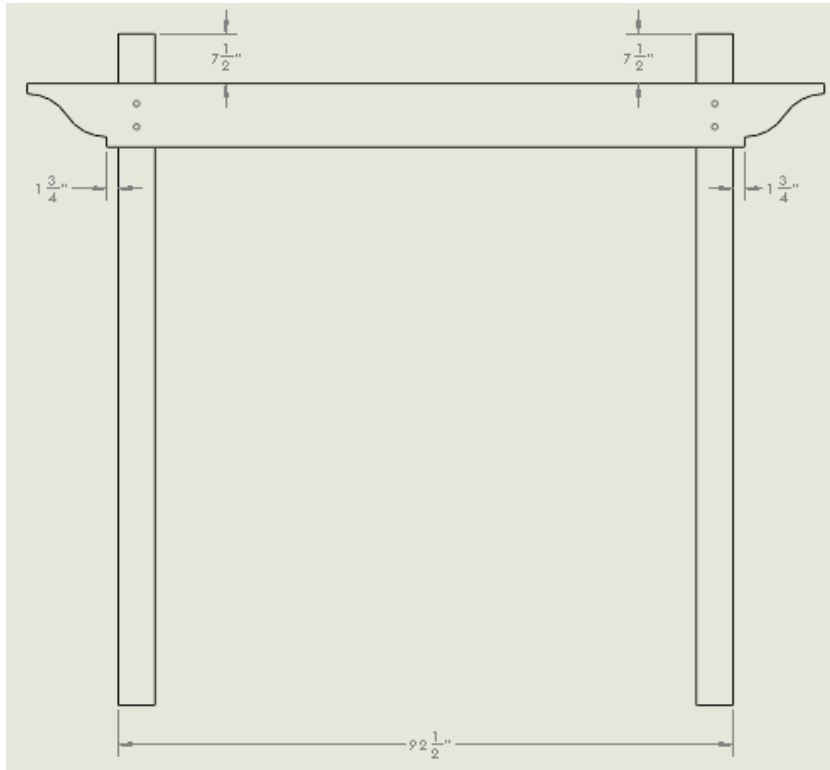

Assemble two 3x10 Headers on both sides of post using provided hardware

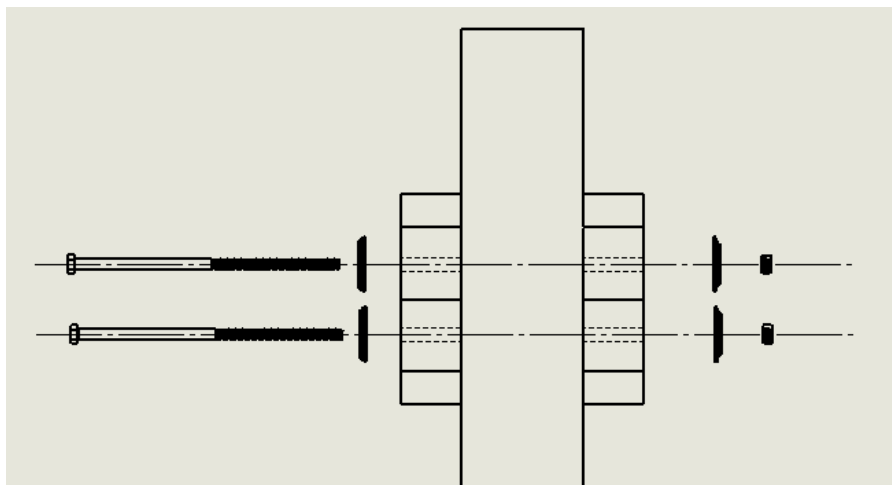

Repeat for remaining two posts and 3x10 headers

#### 4) Hoist Assembled Posts and Headers into Anchors

Prepare four scrap 2x4 to temporarily brace the posts after being hoisted into place. Hoist one post and header structure upright and place bottom end of posts into anchors. Use a level to ensure that posts are plumb and secure into anchors with choice of hardware. Consult Simpson installation instructions for proper procedure. Brace the posts laterally using 2x4 to keep them from falling over during assembly. Secure the 2x4 braces to both the post and the ground.

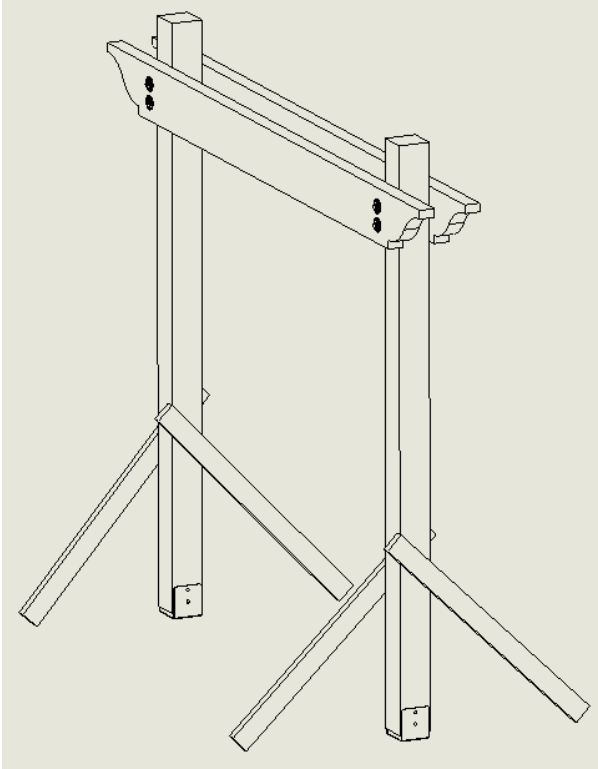

Repeat for opposite side.

**5) Assemble 3x8 Headers**

Place 3x8 Header [3] across top of 3x10 Headers [2]. Center pre-drilled holes upon post and mark location. Drill holes through posts using 7/8" drill bit.

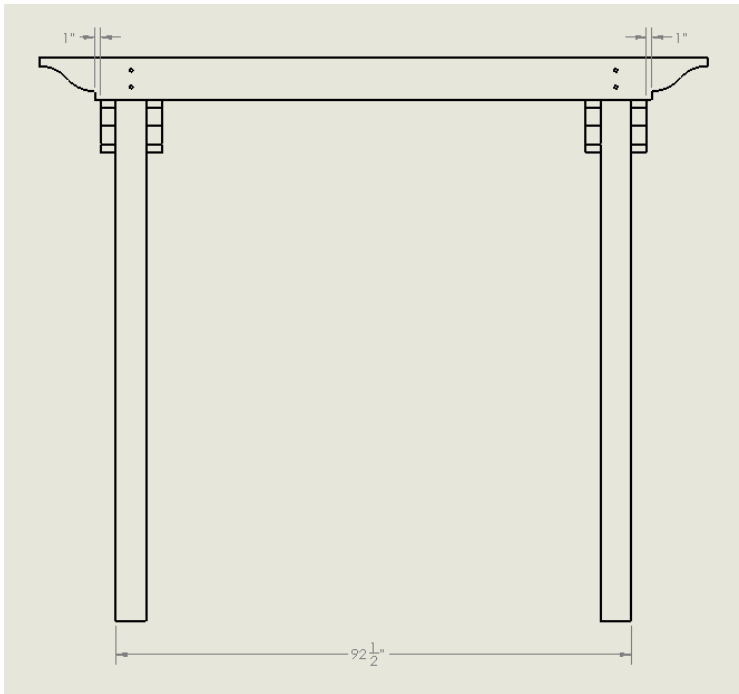

Assemble two 3x8 Headers on both sides of post using provided hardware

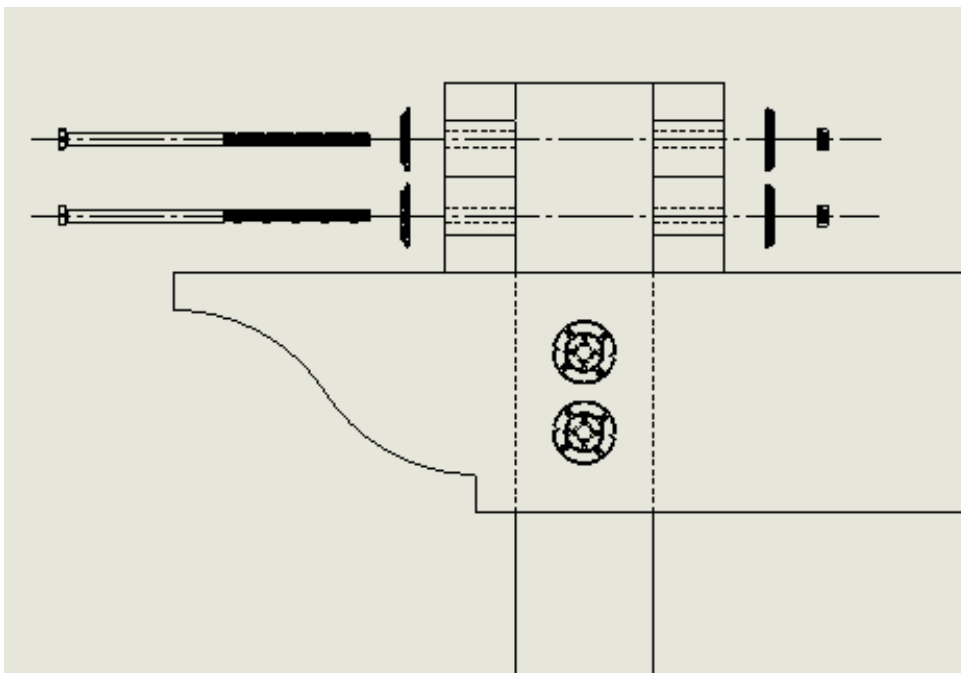

Repeat for remaining two 3x8 headers on opposite side

## 6) Assemble 3x6 Headers

Measure  $15\frac{1}{8}"$  from end of 3x8 Header and locate outside edge of 3x6 Header [4]. Hang over the edge  $7\frac{1}{4}"$  on each side to center the header. Place remaining five 3x6 Headers along length with  $14\frac{5}{8}"$  spacing between each. Secure 3x6 Headers to 3x8 Headers with woodscrews or nails. Pre-drilling pilot holes is recommended to prevent splitting.

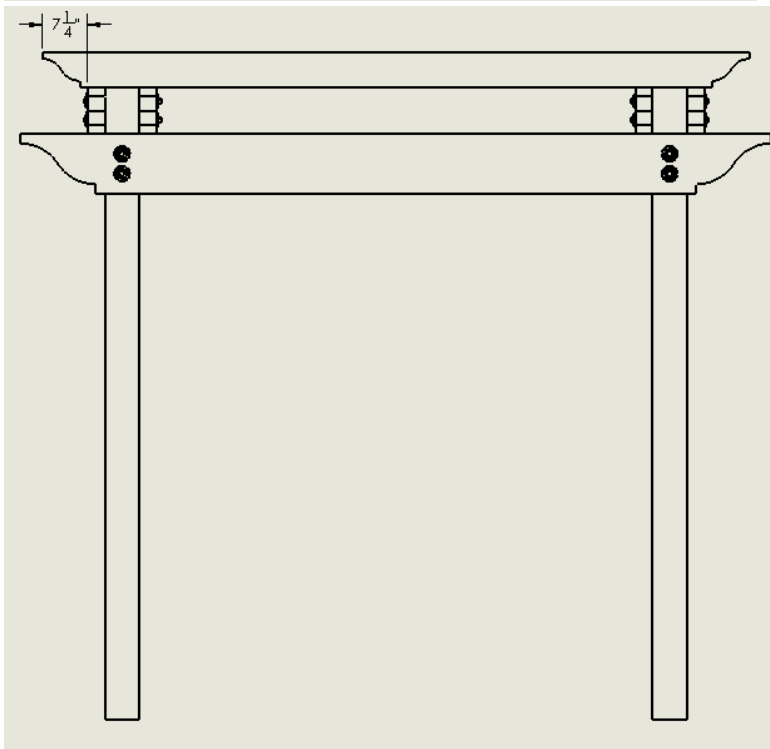
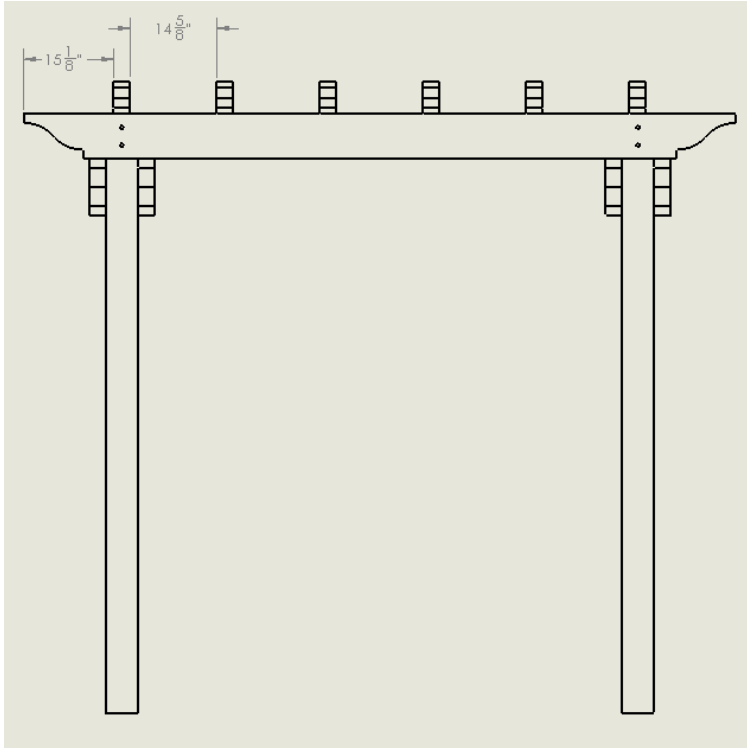

## 7) Assemble Lath

Measure  $3\frac{3}{4}$ " from end of 3x6 Header and locate outside edge of 2x2 Lath [5]. Hang over the edge  $9\frac{3}{16}$ " on each side to center the lath. Place remaining twenty six pieces of 2x2 Lath along length with  $2\frac{1}{2}$ " spacing between each.

Secure 2x2 Lath to 3x6 Headers with woodscrews or nails. Pre-drilling pilot holes is recommended to prevent splitting.

